

REVISIONS				
ZONE	REV	DESCRIPTION	DATE	APPROVED

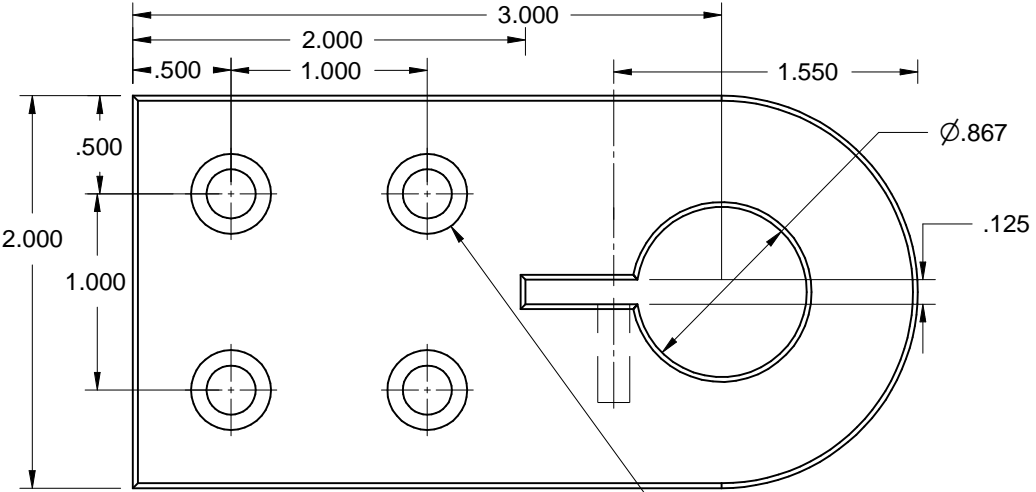
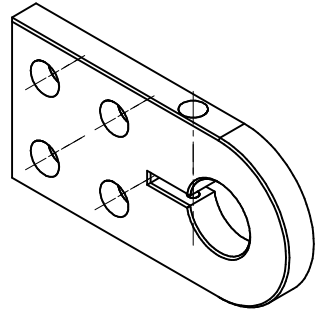
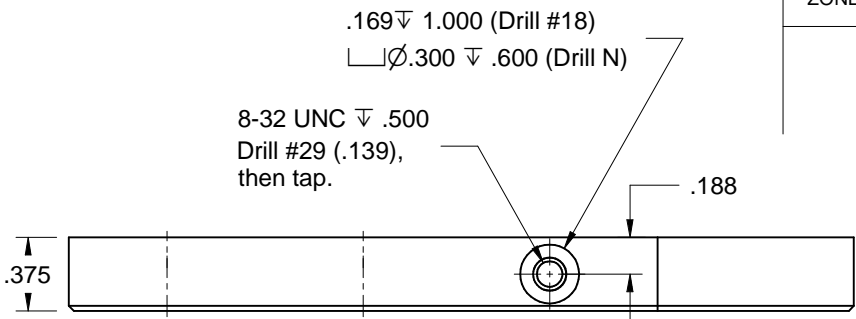

4x Ø.250 THRU
 Chamfer: .125 x .250

Chamfer top edge 0.050" Support screws = 1/4-20 x 3/4" SHCS Clamp screw = 8-32 x 3/4" SHCS Finish: anodize	DRAWN mpogue	DATE	<h2 style="text-align: center;">Bearing support plate</h2>			
	CHECKED					6061-T6 Aluminum Precut 4.0 x 2.0 x 3/8" plate
	QA		SIZE A	FSCM NO.	DWG NO. 001-0004	
	APPROVED		SCALE 1:1	SHEET 1 of 1		